

EXCHANGE RATE REGIME IN A CRISIS: THE CASE OF AZERBAIJAN

Elnara Robertqizi Samedova

Azerbaijan State University of Economics (UNEC), Azerbaijan

Sevda Kerimqizi Mamedova

Azerbaijan State University of Economics (UNEC), Azerbaijan

Mehriban Shabanqizi Aliyeva

Azerbaijan State University of Economics (UNEC), Azerbaijan

Mehriban Tofiqqizi Samadova

Azerbaijan State University of Economics (UNEC), Azerbaijan

Leman Aydinqizi Kashiyeva

Azerbaijan State University of Economics (UNEC), Azerbaijan

ABSTRACT

This study aims to substantiate the practicality of establishing a fixed exchange rate (FER) under external shocks to the Azerbaijani economy. Using regression analysis, principal component analysis, and the Granger causality test, we substantiated the inexpediency of a fixed FER for the manat (the national currency) due to: the ineffective fiscal and monetary policy of the state, weak integration into the U.S. economy, distrust of the manat in the population, and the weakness of currency hedging. Artificial retention of a FER will lead to devaluation and chronic economic recession (inflation growth, a decrease in real incomes of the population, a reduction of GDP per capita, and an increase in unemployment). It is substantiated that an increase in public confidence in the national currency should become the basis for the transition to a floating exchange rate (FER) for the manat as it will help to get the actual value of the manat.

Keywords: currency, fixed exchange rate, floating exchange rate, Azerbaijan, devaluation, external shocks, the manat, crisis

DOI: <http://dx.doi.org/10.15549/jeecar.v9i4.1107>

INTRODUCTION

This study aims to substantiate the practicality of establishing a fixed exchange rate (FER) under

external shocks to the Azerbaijani economy. Using regression analysis, principal component analysis, and the Granger causality test, we

substantiated the inexpediency of a fixed FER for the manat (the national currency) due to: the ineffective fiscal and monetary policy of the state, weak integration into the U.S. economy, distrust of the manat in the population, and the weakness of currency hedging. Artificial retention of a FER will lead to devaluation and chronic economic recession (inflation growth, a decrease in real incomes of the population, a reduction of GDP per capita, and an increase in unemployment). It is substantiated that an increase in public confidence in the national currency should become the basis for the transition to a floating exchange rate (FER) for the manat as it will help to get the actual value of the manat.

INTRODUCTION

There is a manifestation not of sudden shocks (geopolitical shocks) but a combination of increasing long-term structural threats - geopolitical, economic, and existential - and their long-term consequences for the world economy as a whole and individual national economies can hardly be overestimated. The events that have taken place over the past years, particularly the spread of the COVID-19 pandemic, the war in Ukraine, the threat to food security, climate change, increasing poverty, and others, force us to study in more depth the foundations of the instability of emerging market economies. Just the war in Ukraine has caused a massive decline in supply in the global economy, and the shock caused by the war has undermined the foundations for economic growth and increased inflationary expectations, which are becoming more unmanageable globally (Caldara et al., 2022). Global inflation by the end of 2022, according to the latest forecasts, may reach 7.9% (Liuima, 2022). Under the current conditions, as scientists note, economic stability should, first of all, be based on an effective exchange rate regime to minimize the destructive impact of external shocks on the national economy.

Azerbaijan had experience in introducing a floating exchange rate regime for the national currency, doing that in 2017 (Hasanov, 2017). The Central Bank used a new mechanism for currency auctions, beginning as a one-sided currency sale in competitive conditions. This led to an increase in the supply of foreign currency compared to its demand and allowed the manat to strengthen. But starting from the end of the

year, falling oil prices again significantly increased the pressure on the national currency, forcing the adaptation of the foreign exchange market and the manat exchange rate to new oil prices.

Global price growth triggers inflationary processes in Azerbaijan as well. According to the latest forecast data from Fitch Ratings, the inflation rate in the country is expected to be 11.7% in 2022, with an additional increase in the discount rate by 0.25 percentage points by the end of the year (Fitch Ratings, 2022). Because of the significant inflationary burden on the national economy, a fixed exchange rate of the manat against hard currencies in the conditions of a resource-based economy can exacerbate the negative consequences of the crisis at the macroeconomic level and lead to profound economic shocks in the country (International Monetary Fund, 2019).

Undoubtedly, the country's national economy feels inflationary pressure against the backdrop of the Ukrainian crisis, but it positively affects Azerbaijan. In the first five months of 2022, Azerbaijan's GDP increased by 7.2% compared to the previous period due to the rapid growth of oil prices in the global energy market and consumer demand growth (State Statistical Committee of the Republic of Azerbaijan, 2022). At the same time, new avenues began to open up for Azerbaijan. Many European countries today consider the country a potential and reliable supplier of energy resources in its plans to expand the transportation of gas from the Caspian Sea to European countries using the Southern Gas Corridor (Trans Adriatic Pipeline, 2022). One gets the impression that the situation in the world energy market guarantees the stability of Azerbaijan's manat and economy.

Today, the world economy and the energy market are under the constant influence of external geopolitical, economic, and other shocks. European countries and the United States are actively developing new strategic policies, the implementation of which will further contribute to the weakening of energy independence from Russian gas and the stabilization of prices for energy resources. Already today, there has been a collapse in demand, while oil and the price of the European reference grade Brent crude oil have fallen below the \$100 mark (but remains almost 70% higher than planned in the Azerbaijani budget) (Krauss,

2022; State Statistical Committee of the Republic of Azerbaijan, 2022). In general, it is difficult to predict the situation in the oil market. For example, according to the latest J.P. Morgan Chase forecast, the price of a barrel of Brent crude may shortly soar to \$190-380 (Reuters, 2022). At the same time, and contrarily, the American bank Citigroup has predicted a price reduction to 65-45 dollars (Cheong, 2022).

Oil prices are rising on a complex geopolitical agenda, driven by Russia's invasion of Ukraine and OPEC decisions. But if the price of oil suddenly dropped below the \$50 budgeted in Azerbaijan, pressure on the manat would lead to a risk of the devaluation of the exchange rate (Ministry of Finance Republic of Azerbaijan, 2022). So, the stability of the manat has nothing to do with the government's policy or the measures taken by the authorities to maintain the rate of the manat; it is the result of the positive impact of exclusively external shocks. But the Ukrainian crisis creates new external inflationary risk shocks caused by threats to food security, demanding sanctions against Russia, etc., which threaten the devaluation of the manat or enormous government spending to maintain the manat exchange rate. Therefore, the practicality of a fixed exchange rate of the manat is questionable since it exposes the country's economy to high-amplitude fluctuations and negative macroeconomic consequences. This paper's focus, then, is to substantiate Azerbaijan's effective exchange rate regime, taking into account the peculiarities of the development of the national economy, the system of external shocks that characterize the modern global economy, and the political priorities of the state.

LITERATURE REVIEW

Grubic and Schuster (2015) noted in their studies that for developing economies, the most acceptable exchange rate regime is the introduction of a fixed exchange rate. Due to the institutional weakness of the economy, a fixed exchange rate can contribute to the stability of import prices even at high inflation rates. A fixed exchange rate reduces expectations, simplifies trade relations between countries, and contributes to the country's investment attractiveness, provided (according to Robert Mundell's optimal currency area model) that interest rates and inflation should be equivalent

in countries with a fixed exchange rate (Mundell, 1961). For example, based on the fixed exchange rate, China sets the exchange rate below the market rate, limiting import trade flows into the country and thereby expanding exports (White & Zhou, 2019). Azerbaijani economists are also supporters of a fixed exchange rate. According to Akram Hasanov, if the Azerbaijani economy completely switched to a floating exchange rate, this would lead to a sharp and robust devaluation of the manat (Hasanov, 2011). Mukhtarov et al. (2019) supported the same view, supposing Azerbaijan entirely switches to a floating exchange rate for the national currency. In that case, the floating exchange rate implies removing restrictions on banks; consequently, they will be able to set the exchange rate at their discretion. Undoubtedly, banks will overestimate the exchange rate as much as possible. Thus, the manat rate would be set by the market, which would lead to a sharp devaluation of the national currency. The danger is that the national currency may fall sharply in value.

The increased mobility of capital on a global scale and the manifestation and history of financial-economic crises in Turkey, Mexico, Brazil, and Russia, and in the countries of East Asia, have shed light on many destructive factors of a fixed exchange rate in emerging markets (Obstfeld, Ostry & Qureshi, 2019; Hrebennikova et al., 2021; Gulaliyev et al., 2019). Ghosh and Kumar (2022) presented a different view about discrediting the role of fixed exchange rates as an effective tool to fight inflation and ensure economic resilience and growth over external shocks. Artificially undervaluing the exchange rate provides a short-term effect of trade advantage, as it leads to higher prices in the domestic market and thereby reduces the purchasing power in the country (Obstfeld, Ostry & Qureshi, 2019).

Nabli and Véganzones-Varoudakis (2002) noted that the overvaluation of the nominal exchange rate to compensate for import inflation ultimately leads to a decrease in competitiveness and real incomes. Some have argued that a fixed exchange rate is not viable in globalized trade relations because it increases the economy's volatility, in contrast to a floating exchange rate, especially in a developing market, where a colossal shadow currency market can exist (Rohit & Dash, 2019).

Obstfeld, Ostry, and Qureshi (2019) and Ghosh and Kumar (2022) empirically substantiated that fixing the national currency's exchange rate to a hard currency provokes an outflow of capital from the country and massive central bank interventions in domestic foreign exchange markets to maintain exchange rate stability.

Friedman and Hoffman believed that a floating exchange rate in an open developing economy provides flexibility in responding to external shocks, protecting the national economy from a sharp drop (Friedman, 1953; Mundell, 1963; Hoffman, 2007).

Floating exchange rates make it possible to establish the actual value of the national currency, depending on the development level of the economy and, therefore, provide protection for the national economy from external shocks and automatically correct it internally (rates of exports and total expenditures, etc.) (Ghosh & Kumar, 2022). And it does not require the intervention of monetary and fiscal policy. Empirical studies have shown that a 1% reduction in global GDP leads to a decrease in production in developing economies with a fixed exchange rate of 0.67 percentage points (pp) and a floating one of 0.4 pp. (Hoffman, 2007; Ghosh & Ostry, 2009).

Unconditionally floating exchange rates also can negatively influence the national economy and entail costs for the economy by deterring investment and international trade. (CFI, 2022). They are also unpredictable and unstable, but at the same time, their significant fluctuations in the exchange rate have little effect on the state and economic development (Ghosh & Kumar, 2022). Based on the experience of developing countries over the past few years, one can testify to the significant benefits of a floating exchange rate regime. (Obstfeld, Ostry & Qureshi, 2019). These statements can be controversial. It seems that further empirical research on a country-by-country, case-by-case basis is necessary for the conclusions to be more or less reliable and could form the base of the concept of a fixed exchange rate for developing countries.

METHODOLOGY

We used quarterly data on the exchange rate of the Azerbaijani manat against the U.S. dollar, indicators of economic and political development in the country and the world that

affect the exchange rate from 2000 to 1 quarter of 2022 (World Bank, 2022; State Statistical Committee of the Republic of Azerbaijan, 2022; Ministry of Finance Republic of Azerbaijan, 2022) (Table 1)

We used exports and imports of goods and services in general. Mineral fuels, minerals oils, and products of theirs, in particular, were used, the exports of which account for 76.8-97.1% of Azerbaijan's total exports for 2000-2021 and 28.1- 56.1% of the country's GDP (State Statistical Committee of the Republic of Azerbaijan, 2022). Exporting goods and services increases the supply of foreign currency in the domestic market (with unchanged monetary and fiscal policy, socio-economic, and political development indicators) (Grubacic & Schuster, 2015).

The indicators that determine the supply and demand for foreign currency are a foreign investment, the international transfers of individuals, and the amount of public debt. Inflation decreases the national currency's purchasing power and leads to devaluation (Grubacic & Schuster, 2015). Also, the exchange rate is influenced by monetary policy instruments: the discount rate, the reserve ratio, the volume of international reserves, foreign exchange interventions, and the difference in discount rates between countries (Ghosh & Kumar, 2022). For comparison, the discount rates of the countries that are the main trading partners of Azerbaijan (Italy, Turkey, Russian Federation, China) and the discount rates of Great Britain, and the USA, which are the leading foreign investors for Azerbaijan, were used (State Statistical Committee of the Republic of Azerbaijan, 2022).

We also considered the indicators of GDP per capita, the index of real incomes of the population, the unemployment rate, the country's credit rating, voice and accountability, political stability and absence of violence/terrorism, government effectiveness, regulatory quality, the rule of law, control of corruption (Grubacic & Schuster, 2015).

Table 1: Indicators that determine the exchange rate of the manat

Designation	Indicators
<i>The internal conjuncture of the economy</i>	
EXP_G	Exports of goods, current billion USD
EXP_S	Exports of services, current billion USD
EXP_O	Exports of mineral fuels, minerals oils, and products of their current billion USD
IMP_G	Imports of goods, current billion USD
IMP_S	Imports of services, current billion USD
FDI_{IN}	Foreign direct investment, inflows (current billion USD)
POR_{IN}	Portfolio investment, inflows (current billion USD)
OT_{IN}	Other assets, inflows (current billion USD)
FDI_{FROM}	Foreign direct investment, outflows (current billion USD)
POR_{FROM}	Portfolio Investment, outflows (current billion USD)
OT_{FROM}	Other investments, outflows (current billion USD)
$TRANSF_{TO}$	Personal remittances received (current billion USD)
$TRANSF_{FROM}$	Personal remittances paid (current billion USD)
$DEBT$	External debt stocks, current billion USD
$PRICE$	Consumer price index, %
$RATE$	Discount rate, %
$\Delta RATE_{IT}$	Absolute deviation of the discount rate (Azerbaijan/Italy, pp)
$\Delta RATE_{TUR}$	Absolute deviation of the discount rate (Azerbaijan/ Turkey, pp)
$\Delta RATE_{RUS}$	Absolute deviation of the discount rate (Azerbaijan/ Russia, pp)
$\Delta RATE_{CH}$	Absolute deviation of the discount rate (Azerbaijan/China, pp)
$\Delta RATE_{UK}$	Absolute deviation of the discount rate (Azerbaijan/United Kingdom, pp)
$\Delta RATE_{USA}$	Absolute deviation of the discount rate (Azerbaijan/USA, pp)
$RESERV$	International reserves, current billion USD
$INTERV$	Currency interventions. The value of the indicator is "0" if there were no foreign exchange interventions, "-5" - when buying foreign currency, "5" - when selling
RES_{LE}	Reserve requirements of the Central Bank of Azerbaijan on deposits of legal entities in foreign currency, %
RES_{HOUS}	Reserve requirements of the Central Bank of Azerbaijan on deposits of households in foreign currency, %
$DEMAND$	Foreign currency sales, current billion USD
$DEPOS$	Foreign Currency Deposit, current billion USD
GDP	GDP per capita, current USD
INC	Actual average monthly wage index, %
$UNEMPL$	Unemployment rate, %
RAT	Credit Rating S&P, points. "0" points - rank D, "5" points - C, "10" points - CC, "15" points - CCC-, etc. + "5" points for each highest ranking position
$VOICE$	Voice and Accountability
$STAB$	Political Stability and Absence of Violence/Terrorism
$EFFECT$	Government Effectiveness
$REGUL$	Regulatory Quality
LAW	Rule of Law
COR	Control of Corruption
<i>The external conjuncture of the economy</i>	
PRo	Brent oil spot prices, US\$100/bbl
PRg	Natural gas spot prices, USD / Mmbtu
PRa	Agricultural producer price index, %
$INFEC$	Number of new confirmed COVID-19 cases in the world
$LIMIT$	Number of countries where the lockdown is in effect
$INFECc$	Number of countries where cases of COVID-19 infection have been recorded since the beginning pandemic

Table 1: Continued

<i>FIN</i>	Total assets of global financial institutions, trillion USD
<i>DEBT_w</i>	World external debt stocks, trillion USD
<i>GDP_w</i>	World GDP per capita, current USD млрд.
<i>UNEMPL_w</i>	World unemployment rate, %
<i>POV</i>	The proportion of the population below the international poverty line (%)

Source: Authors' finding

Among the external factors, we used world prices for oil and gas as goods that occupy the largest share in Azerbaijan's international trade structure and which significantly reacted to the global financial-economic crisis of 2008-2009, the humanitarian crisis caused by the COVID-19 pandemic, and military conflicts (World Bank, 2022). The world agricultural producer price index characterizes food security risks due to the Ukraine war (Baghirov et al., 2022). The number of people infected with COVID-19, countries with cases of infection, and quarantine restrictions are indicators characterizing the spread of the COVID-19 pandemic (Megits, Neskorođieva & Schuster, 2020; Vasiljeva et al., 2020). The volume of global financial assets and the amount of public debt characterize the level and cost of external lending. (Grubacic & Schuster, 2015).

Developing the research algorithm involved several stages.

1) Determination of external shocks and internal factors affecting the exchange rate used

$$\left\{ \begin{array}{l} \text{Exchange} = k_1 \times Sh_1 + k_2 \times Sh_2 + \dots + k_n \times Sh_n + \text{constant} \\ Sh_i = f \left(\sum_{j=1}^m l_j \times I_j \right) \\ n = \{Sh_1, Sh_2, \dots, Sh_i \mid e_i \geq 1.0\} \\ m = \{I_1, I_2, \dots, I_j \mid l_j \geq |0.7|\} \end{array} \right. \quad (1)$$

Where *Exchange* - the exchange rate of the Azerbaijani manat to the U.S. dollar;

k_n - weight coefficients;

Sh_i - the value of the i-th factor/shock affecting the exchange rate;

l_j - factor loading of the j-th indicator forming the i-th factor/shock;

I_j - the value of the j-th indicator;

e_i - the eigenvalue of the i-th factor/shock;

n - number of significant factors/shocks;

m - number of indicators forming the i-th factor/shock

Using the values of principal components rather than indicators (Table 1) in assessing the impact on the exchange rate made it possible to avoid multicollinearity in the model. The correlation coefficients of the principal

the principal component analysis (PCA) and Statistica 12.0 program. The Kaiser criterion combined them into principal components (Table 1). Factor loadings were not lower than |0.7| (Menke, 2018).

2) Determination of cause-and-effect relationships between the principal components, EViews 10. The Dickey-Fuller test checked stationarity, and the Granger causality test was used. Cause-and-effect relationships were selected at significance at a level of 0.1.

3) Assessing factors' influence on the exchange rate using the regression analysis method (formula 1). The values of the principal components calculated and the Azerbaijani manat chain growth rates against the U.S. dollar were used as variables. Using regression models, we assessed the impact of the exchange rate on the socio-economic development of Azerbaijan

components do not exceed |0.08|.

RESULTS

The key factors influencing the exchange rate dynamics were identified (Table 2). The

statistical significance we confirmed by the cumulative percentage of the variance of the selected factors, which exceeds 80% (Menke, 2018).

Table 2: Factors influencing the exchange rate of manat

Factors	Indicators describing the factors	Dispersion, %
Factors affecting the exchange rate		
Monetary factor (<i>Monetar</i>)	$RATE, \Delta RATE_{IT}, \Delta RATE_{TUR}, \Delta RATE_{RUS}, \Delta RATE_{CH}, \Delta RATE_{UK}, \Delta RATE_{USA}, INTERV, RES_{LE}, RES_{HOUS}$	20.9
Macroeconomic factor (<i>Macro</i>)	$DEBT, PRICE, GDP, INC, UNEMPL, RESERV, RAT$	15.9
The factor of decrease in investment volumes (<i>Invest</i>)	$FDI_{IN}, POR_{IN}, OT_{IN}, FDI_{FROM}, POR_{FROM}, OT_{FROM}$	14.3
The factor of decrease in export volumes (<i>Export</i>)	$EXP_G, EXP_S, EXP_O, IMP_G, IMP_S$	14.1
Political factor (<i>Polit</i>)	$STAB, EFFECT, REGUL, VOICE, LAW, COR$	8.4
Behavioral factor (<i>Behav</i>)	$DEMAND, DEPOS$	7.6
The factor of decline in remittances to the country (<i>Transfer</i>)	$TRANSF_{TO}, TRANSF_{FROM}$	7.1
Cumulative dispersion, %		88.3
Shocks affecting the exchange rate		
Price (<i>SHpr</i>)	PRo, PRg, PRa	29.2
Socio-economic (<i>SHsc</i>)	$GDPw, POVw, UNEMPLw$	23.9
The socio-demographic shock caused by the COVID-19 pandemic (<i>SHcov</i>)	$INFEC, LIMIT, INFECc$	14.3
Financial (<i>SHfin</i>)	$FIN, DEBTw$	
Cumulative dispersion, %		86.2

Source: Authors' finding

Decreasing investment creates the risk of devaluation of the national currency due to a reduction in investments in the country, which generate the supply of foreign currency.

The export decline factor reflects the risk of currency devaluation due to shortfalls in export earnings. The trouble is due to a decrease in the export income of mineral fuels, minerals, oils, and products of their own. This indicator has the most significant impact on exchange rate dynamics in Azerbaijan. Fluctuations in commodity prices and export volumes are one of the primary sources of macroeconomic volatility in resource-based economies (Pönkä & Zheng, 2019)

The macroeconomic factor is associated with a decrease in the country's investment attractiveness (due to a reduction in GDP per capita, rising unemployment, a decline in real personal incomes, and decreased purchasing

activity due to inflation). The decrease in remittances creates a threat of devaluation of the Azerbaijani manat due to the outflow of foreign currency in the form of remittances from the country. The political factor creates the risk of currency devaluation due to a decrease in investment attractiveness through political instability and inefficiency of state policy. The economic factor reflects the impact on the exchange rate of instruments of monetary market regulation by the government.

Behavioral factors included the volume of foreign currency purchased by individuals, all entities, non-financial institutions, and foreign currency deposits. Prolonged inflation, rising unemployment, and political instability give rise to uncertainty in the national currency, which stimulates the demand for foreign currency, reducing the need for the manat. Households can form this demand to save from depreciation

(panic demand) and speculators to profit from currency transactions (speculative market).

Among the shocks affecting the exchange rate are:

- Price, which characterizes the change in economy and exchange rate under the influence of the trend of oil price, gas, of agricultural products;
- Socio-economic - reflect changes in the global economy and the living standard of the population;
- Financial - is manifested through the influence of external lending volume and its cost on the exchange rate;

- The socio-demographic shock caused by the COVID-19 pandemic is highlighted separately since, in addition to the negative impact on the global economy due to social distancing and high mortality rates, the pandemic has affected the behavior of investors and households (Megits, Neskorodieva & Schuster, 2020).

The assessment model of the impact of external shocks on the exchange rate is shown in Fig. 1. Cause-and-effect relationships are significant according to the Granger test and the *t* and *F*-criteria for regression models.

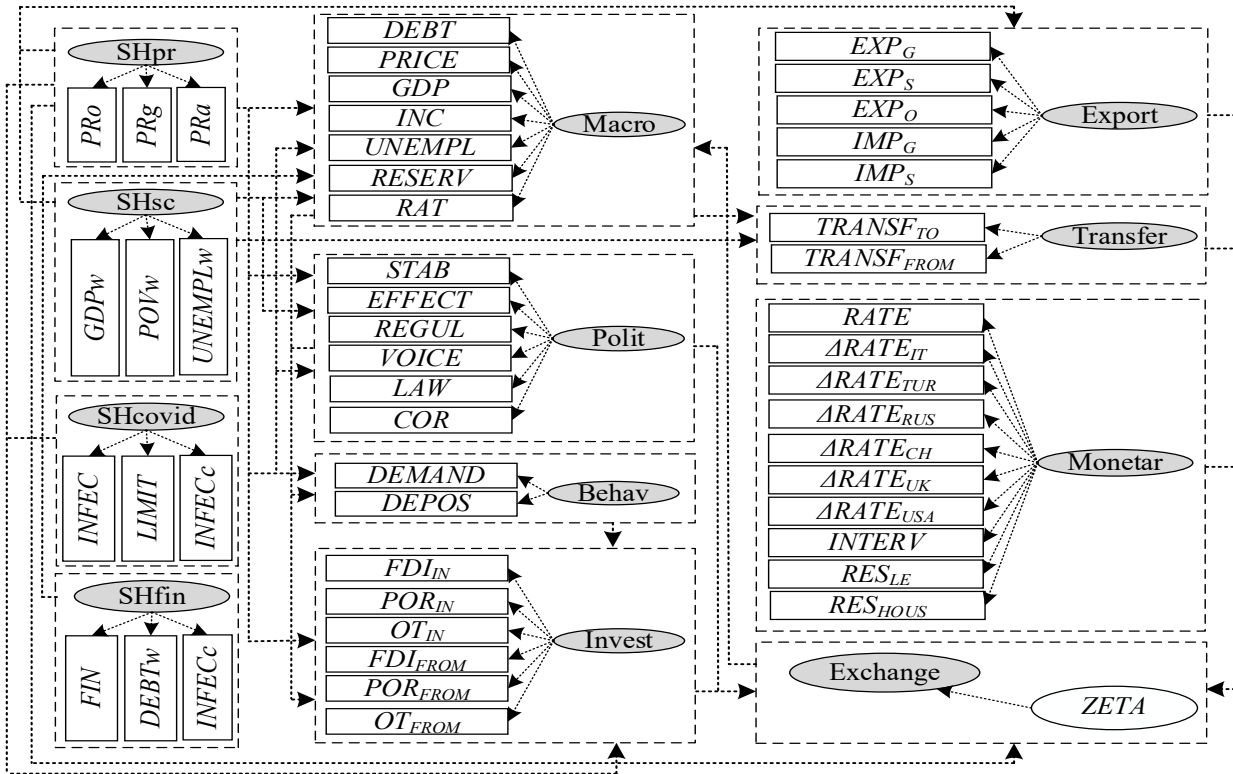

○ - latent variables; ○ - model errors; □ - explicit variables ⤴ - causal relationship

$$Export = -0.41 \times SHpr + 0.17 \times SHsc + 0.16 \tag{1}$$

(0.0001) (0.0372)

$$Transfer = 0.33 \times SHsc + 0.30 \times Macro - 0.83 \tag{2}$$

(0.0008) (0.0010)

$$Behav = 0.18 \times SHcov + 0.39 \times Macro + 0.22 \times Polit - 0.93 \tag{3}$$

(0.0163) (0.0005) (0.0084)

$$Invest = -0.32 \times SHpr + 0.11 \times SHcov + 0.22 \times Macro + 0.16 \times Polit + 0.28 \times Behav - 1.05 \tag{4}$$

(0.0008) (0.0250) (0.0095) (0.0115) (0.0021)

$$Macro = -0.36 \times SHpr + 0.28 \times SHsc + 0.20 \times SHfin + 0.12 \times SHcov - 0.11 \tag{5}$$

(0.0012) (0.0189) (0.0226) (0.0336)

$$Polit = -0.31 \times SHpr + 0.22 \times SHsc + 0.20 \times SHcov + 0.14 \tag{6}$$

$$\begin{matrix} (0.0164) & (0.0205) & (0.0288) \\ \text{Exchange}=0.51 \times \text{SHpr} + 0.43 \times \text{Behav} + 0.15 \times \text{Transfer} + 0.23 \times \text{Invest} + 0.42 \times \text{Monetar} + 0.17 \times \text{Export} - \\ 1.11 \end{matrix} \quad (7)$$

$$\begin{matrix} (0.0001) & (0.0006) & (0.0840) & (0.0679) & (0.0007) & (0.0773) \\ \text{Exchange} = -0.17 \times \text{RATE} + 8.39 \times \text{RESERV} - 3.75 \end{matrix} \quad (8)$$

$$\begin{matrix} (0.0134) & (0.0005) \\ \text{Macro} = 0.14 \times \text{Exchange}' - 0.06 \times \text{Exchange} + 1.05 \\ (0.0073) & (0.0310) \end{matrix} \quad (9)$$

Figure 1: Model for assessing the impact of external shocks on the exchange rate of the Azerbaijani manat

The variable significance level was indicated in parentheses.

Source: Authors' finding

To assess the effectiveness of the existing fixed exchange rate manat, we used regression models to determine the impact of the fixed exchange rate on the country's socio-economic development (Fig. 1, formulas 1-9). The adequacy of the constructed models is confirmed by the t and F -criteria, which are statistically significant at a significance level of 0.01, 0.05, and 0.1. The devaluation in the face of the negative impact of external shocks leads to high inflation, a decrease in the real incomes of the population, and real GDP per capita. A polynomial function describes this influence.

DISCUSSION

It has been empirically proven that external shocks directly affect the state of the Azerbaijani economy because of its integration into the global economic space and, therefore, have an impact on the exchange rate of the manat. The most significant is the impact of the price shock. The decline in oil and gas prices, as well as the rise in prices for agricultural products, leads to a decrease in export earnings, the investment attractiveness of Azerbaijan, and the destabilization of the macroeconomic and political situation. The resource-based economy and the low level of diversification explain the manat's strong dependence on the oil price. And the presence of a fixed exchange rate regime further exacerbates this dependence, which many scientists have proved (Obstfeld, Ostry & Qureshi, 2019).

A socio-economic shock leads to similar consequences, which also causes a decrease in remittances to the country due to a reduction in donor income. The impact of the financial shock is manifested through a macroeconomic factor, a decline in the country's international reserves.

The socio-demographic shock caused by the COVID-19 pandemic provoked a decrease in GDP per capita in Azerbaijan, an increase in unemployment, inflation, a reduction in real incomes of the population, and a decline in investors' revenue. It also negatively affected the effectiveness of state regulation due to the growth of unplanned government spending related to the pandemic and a decrease in income through a reduction of demand for energy resources, their cost, and a drop in revenue from the service sector and tourism.

The above factors give grounds to assert that today, due to the destructive impact of external shocks on the state of the Azerbaijani economy, the fixed exchange rate of the manat indicates its overvalued value. A significant level of devaluation of the manat will be expected if the downward trend in the price of oil in the world energy market changes.

The results obtained correlate with other researchers' conclusions about the inefficiency of fiscal and monetary policy in developing countries (Ghosh & Kumar, 2022). The country's strategic foreign exchange reserves continue to grow against a surplus in the balance of payments. Crisis manifestations of the global environment and a change in Europe's energy strategy threaten the balance of Azerbaijan's foreign exchange market in the medium and long term. For example, in August 2022, European energy giants left the project, which provides for the transportation of 40 to 50 billion euros worth of Azerbaijani gas to Europe (U.S. Department of State, 2022). This suggests that investors are aware of the impending devaluation, and it can be expected that, soon, the reserves of the Central Bank of Azerbaijan will become significantly smaller against the backdrop of liquid capital fleeing the country. And it will not

be possible to quickly improve the trade balance due to the impact of the pandemic on trade supply chains and the slowdown in global economic growth and war.

Particularly noteworthy is the empirical assessment of the significance of the negative impact on the exchange rate of the behavioral factor, which, in terms of its effect on the stability of the exchange rate, ranks second after the price of crude oil. The longer the time of economic or political instability, the more significant is the panic and speculative demand for foreign currency. If there are prerequisites for currency devaluation, individuals and legal entities begin to exchange it for more stable ones, thereby worsening the position of the weakened currency. The results confirmed the behavioral theory's validity in determining the exchange rate dynamics. We indicated that the insufficient level of household deposits in national currency in Azerbaijani banks and the high level of demand for foreign currency, especially U.S. dollars, led to the fact that the dollarization of household deposits increased to 42.3% in January-March 2022, which may indicate the mistrust of Azerbaijanis to the fixed exchange rate of the manat (State Statistical Committee of the Republic of Azerbaijan, 2022).

The influence of other determining factors on the exchange rate for manat is significant at 0.1; it showed a weak connection with the manat exchange rate and, therefore, exposes the doubt of its fixed exchange rate as its actual value.

The studied external shocks did not significantly impact the monetary factor associated with Azerbaijan's fixed exchange rate. For this reason, among the factors that form the exchange rate, one of the most significant (a significance level of 0.01) is the monetary factor. Its influence is manifested through monetary policy instruments that regulate the exchange rate (discount rate, foreign exchange interventions). Increasing the discount rate leads to an increase in the interest of investors in investing money and, as a result, a revaluation of the national currency. With an increase in the discount rate by 1 pp. (the base rate is from April 1, 2022), the value of the Azerbaijani manat increased by 0.81%. This takes into account the fact that from 2000 to the first quarter of 2022, the range of discount rate values was 13 pp, and the possibilities for stabilizing the currency through the discount rate are limited (State

Statistical Committee of the Republic of Azerbaijan, 2022).

Foreign exchange intervention is a more effective instrument of influence on the exchange rate, manifested through changes in the volume of international reserves. A decrease in international accounts by 1% compared to the value as of January 4, 2022, with the level of other factors remaining unchanged, allows the manat rate to increase in the short term by 4.10%. But such measures lead to a decrease in international reserves, which is a more extended period that leads to the devaluation of the national currency. Azeibarzhan had an experience in 2015 where, due to fixing the exchange rate, national reserves were forced to reduce by 10 billion U.S. dollars, causing the devaluation to progress. The global economic crisis of 2014 and the sharp drop in oil prices put the fixed exchange rate of the manat under pressure, provoking the risk of losing the country's reserves, which again confirms our study's results on the ineffectiveness of a fixed exchange rate regime for the national currency, particularly a hard peg of the manat to the U.S. dollar.

CONCLUSION AND RECOMMENDATIONS

Empirically, we have substantiated that the fixed exchange rate in Azerbaijan in current conditions has demonstrated its ineffectiveness under external shocks that characterize the global environment today. In this case, maintaining a fixed exchange rate for a certain period will lead to the devaluation of the manat and an economic downturn, which is more significant with sharp changes in the exchange rate than with gradual ones. The results obtained confirm the point of view of Obstfeld, Ostry, and Qureshi (2019), Ghosh and Kumar (2022), and Rohit and Dash (2019) about the ineffectiveness of the fixed exchange rate, but at the same time, serve as a unique basis for continuing research on this topic since the results are confirmed for a country with a resource-based economy and an emerging market. The research also considered external shocks provoked by the war in Ukraine and the COVID-19 pandemic, which was not reflected in previous studies.

Therefore, the modern economic development of Azerbaijan does not correspond to the practicality of a fixed exchange rate of the national currency against the U.S. dollar, mainly due to the weak integration of the national

economy into the economy of the hard currency country, the institutional weakness of the country, the political priorities of the government in the country, and negative experience using a floating exchange rate. But because the behavioral factor, along with the world oil price, is fundamental, restoring public confidence in the manat can become the basis for a transition to a floating exchange rate regime. To do this, the country's government should focus on strengthening the hedging of currency risks. It is advisable to apply widely such mechanisms as loan guarantees, insurance, and subsidies. State institutions such as the Mortgage and Credit Guarantee Fund, the Enterprise Development Fund, the Innovation Agency, and the Agency for Agricultural Lending and Development alleviate risks by providing subsidies, guarantees, and preferential loans. However, to generally reduce currency risks to a level that will contribute to the effectiveness of a floating exchange rate, it is advisable to continue structural reforms and increase financial depth. In addition, not only banks should ensure currency risks, but also the stock market, the effectiveness of which can be judged based on positive world experience.

Our research was based on the "hard peg" of the manat to the U.S. dollar. But the rate of the manat is also fixed to the exchange rate of hard currencies of other countries of the world. This means we should investigate the specifics of the exchange rate regimes on a case-by-case basis depending on: What external shocks affect the national economy (rising food prices, pandemic, global economic recession, war, demographic crisis, etc.); if the country is a net exporter or importer, etc.; the political priorities of a fixed exchange rate in the country; how integrated the economy is in the economy of a country with hard currency. These issues require fundamental research and will be considered in further study.

REFERENCES

- Baghirov, H., Humbatov, Y. A., Abdullayeva, S., Aslanova, M. M., & Seyidova, S. (2022). Development of human capital and the economy in Azerbaijan in the context of the Russian-Ukrainian war. *Journal of Eastern European and Central Asian Research (JEECAR)*, 9(3), 532-542. DOI:10.15549/jeecar.v9i3.995
- Caldara, D., Conlisk, S., Iacoviello, M., & Penn, M. (2022). The Effect of the War in Ukraine on Global Activity and Inflation. Federal Reserve System. <https://goo.su/tzPRVG>
- CFI. (2022). Floating Exchange Rate. <https://goo.su/V9yO>
- Cheong, S. (2022). Citi Says Oil May Collapse to \$65 by the Year-End on Recession. Bloomberg. <https://goo.su/KPJF>
- Fitch Ratings. (2022). Fitch Affirms Azerbaijan at 'BB+'; Outlook Stable. <https://goo.su/Cbn9SAh>
- Friedman, M. (1953). *The Case for Flexible Exchange Rates*. Chicago: Chicago University Press.
- Ghosh, R., & Ostry, J. (2009). Choosing an Exchange Rate Regime. IMF.
- Ghosh, T., & Kumar, S. (2022). The effectiveness of macro-prudential policies in the face of global uncertainty – the role of exchange-rate regimes. *Finance Research Letters*, 46, Part A, 102358
- Grubacic, S., & Schuster, J. (2015). Real Exchange Rates in Advanced Transition Economies. *Journal of Eastern European and Central Asian Research (JEECAR)*, 2(2), 11. DOI:10.15549/jeecar.v2i2.102
- Gulaliyev, M.G., Ashurbayli-Huseynova, N.P., Gubadova, A.A., Ahmedov, B.N., Mammadova, G.M., & Jafarova, R.T. (2019). Stability of the banking sector: deriving stability indicators and stress-testing. *Polish journal of management studies*, 19, 2
- Hasanov, A. (2011). *Azerbaijan banking law*. Moscow: Jurisprudence
- Hasanov, R. (2017). *Assessment on Real Effective Exchange Rate in Azerbaijan: 2017 Outlook*. CESD Press. <https://goo.su/vNCH>
- Hoffman, M. (2007). Fixed Versus Flexible Exchange Rates: Evidence from Developing Countries. *Economica*, 74(295), 425-449. DOI:10.1111/j.1468-0335.2006.00564.x
- Hrebennikova, A., Artemchuk, L., Nahorny, V., Daliak, N., & Ruban, O. (2021). Assessment of the Network Interaction Synergistic Effect According to the Organization Life Cycle. *Journal of Eastern European and Central Asian Research (JEECAR)*, 8(3), 311 -323. DOI:10.15549/jeecar.v8i3.754
- International Monetary Fund. (2019). *IMF Executive Board Concludes 2019 Article IV Consultation with the Republic of Azerbaijan*. Press Release No. 19/341
- Krauss, C. (2022). Oil Prices Fall Below \$100 on Weaker Economic Outlook. The New York Times. <https://goo.su/mjC2TK>

- Liujima, J. (2022). Global Inflation Tracker Q2 2022: Energy-Dependent Countries Under Pressure. Euromonitor International. <https://goo.su/SdU9Q>
- Megits, N., Neskorodieva, I., & Schuster, J. (2020). Impact assessment of COVID-19 on trade between Eastern Europe and China. *Journal of Eastern European and Central Asian Research (JEECAR)*, 7(3), 385-399. DOI:10.15549/jeecar.v7i3.579
- Menke, W. (2018). *Factor Analysis. Geophysical Data Analysis (Fourth Edition)*. New York: Academic Press, 207-222.
- Ministry of Finance Republic of Azerbaijan. (2022). <http://www.maliyye.gov.az/en>
- Mukhtarov, S., Yüksel, S., Ibadov, E., & Hamidov, H. (2019). The effectiveness of exchange rate channel in Azerbaijan: An empirical analysis. *Banks and Bank Systems*, 14, 111-121. DOI:10.21511/bbs.14(1).2019.10.
- Mundell, R. (1963). Capital Mobility and Stabilisation Policies under Fixed and Flexible Exchange Rates. *Canadian Journal of Economics and Political Sciences*, 29, 4, 475-485.
- Mundell, R. A (1961). Theory of Optimum Currency Areas. *American Economic Review*, 51, 657-665
- Nabli, M. K., & Véqanzonès-Varoudakis, M.-A. (2002). Exchange Rate Regime and Competitiveness of Manufactured Exports. Working Paper Series No. 27.
- Obstfeld, M., Ostry, J. D., & Qureshi, M. S. (2019). A tie that binds: Revisiting the trilemma in emerging market economies. *Rev. Econ. Stat.*, 101 (2), 279-293
- Pönkä, H., & Zheng, Y. (2019). The role of oil prices on the Russian business cycle. *Research in International Business and Finance*, 50(C), 70-78.
- Reuters. (2022). Oil could hit \$380 if Russia slashes output over the price cap, J.P.Morgan says. <https://www.reuters.com/article/oil-global-jpmorgan-idUSKBN2OF0H1>
- Rohit, A. K., & Dash P. (2019). Dynamics of monetary policy spill-over: the role of exchange rate regimes. *Economic Modelling*, 276-288
- State Statistical Committee of the Republic of Azerbaijan. (2022). <https://www.stat.gov.az/?lang=en>
- Trans Adriatic Pipeline. (2022). The Southern Gas Corridor. <https://goo.su/gjxoZ2>
- U.S. Department of State. (2022). 2022 Investment Climate Statements: Azerbaijan. <https://www.state.gov/reports/2022-investment-climate-statements/azerbaijan/>
- Vasiljeva, M., Neskorodieva, I., Ponkratov, V., Kuznetsov, N., Ivlev, V., Ivleva, M., Maramygin, M., Zekiy, A. (2020). A Predictive Model for Assessing the Impact of the COVID-19 Pandemic on the Economies of Some Eastern European Countries. *Journal of Open Innovation: Technology, Market, and Complexity*, 6(3), 92. DOI:10.3390/joitmc6030092
- White, S., & Zhou, W. (2019). Explainer: How does China manage the yuan, and what is its real value? Reuters. <https://goo.su/MTKom2i>
- World Bank. (2022). <https://data.worldbank.org/indicator>

ABOUT THE AUTHORS

Elnara Robertqizi Samedova, e-mail: elnara_samadova@unec.edu.az

Elnara Robertqizi Samedova, Azerbaijan State University of Economics (UNEC), Department of Economics, Ph.D. in Economics

Sevda Kerimqizi Mamedova, Azerbaijan State University of Economics (UNEC), Department of Economics, Ph.D. in Economics

Mehriban Shabanqizi Aliyeva, Azerbaijan State University of Economics (UNEC), Department of Economics, Ph.D. in Economics

Mehriban Tofiqqizi Samadova, Azerbaijan State University of Economics (UNEC), Department of Economics, Ph.D. in Economics

Leman Aydinqizi Kashiyeva, Azerbaijan State University of Economics (UNEC), Department of Economics, Ph.D. in Economics